

**Pre-Use Checkout**

- WARNING:**
- Only use a size “88” (1,963 liters) cylinder that is marked “MR Conditional. Keep cylinder at 100 gauss or less.” with the INOMax DS<sub>IR</sub> Plus MRI while in the scanner room. Use of any other cylinder may create a projectile hazard.
  - The INOMax DS<sub>IR</sub> Plus MRI is classified as MR Conditional with MR scanners of 1.5 or 3.0 Tesla strength ONLY in areas where the field strength is less than 100 gauss.

(The following instructions are provided for when the on-screen pre-use wizard is not used.)

1. Turn device ON, low calibration will begin and complete (Continue with steps 2-4 while calibration completes)
2. **Initial Connections:**  
Confirm attachment of the following:
  - a. Water separator cartridge, water bottle, and MR conditional patient gas sample line in place.
  - b. MR conditional injector module cable and tubing are connected.
  - c. Plug in power cord and verify AC power light is ON.
  - d. Regulator to INOMAX cylinder.
  - e. Regulator hose to INOMax DS<sub>IR</sub> inlet.
  - f. INOblender hose connected and white lock in place.
  - g. Oxygen source (50 psig) to back of INOblender.
  - h. IR cable in place.
3. Assemble pre-use set-up connectors (diagram on back). Do Not turn on O<sub>2</sub> flowmeter yet.

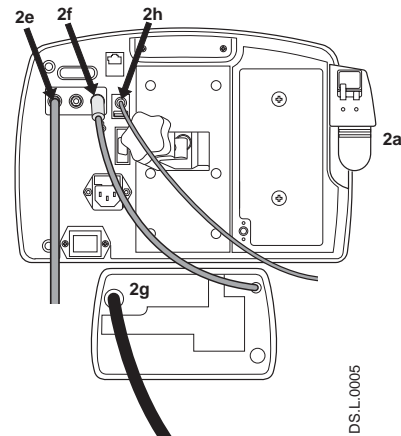

4. **High Pressure Leak Test:**  
Open/close INOMAX cylinder valve.
  - a. Verify, at least 500 psig cylinder pressure.
  - b. Verify, no decrease in cylinder pressure for 30 seconds.
5. **Manual Purge/Alarm Verification:**
  - a. Press CANCEL to exit pre-use wizard (low calibration should be complete to continue).
  - b. Verify INOMAX cylinder valve is closed.
  - c. Set O<sub>2</sub> flowmeter to 10 L/min.
  - d. Purge INOMax DS<sub>IR</sub> Plus MRI.
    - Set the INOMAX dose to 40 ppm.
    - “Cylinder Valve Closed” alarm will occur.
    - Continue until cylinder gauge pressure drops to 0 psig.
    - Measured NO<sub>2</sub> will increase and then decrease as NO<sub>2</sub> is purged from the system.
    - “Low Cylinder Pressure” alarm will occur.
  - e. Turn INOMAX dose to zero.
  - f. Open INOMAX cylinder valve.

6. **Integrated Pneumatic Backup Test:**
  - a. Verify pre-use assembly flowmeter set to 10 L/min.
  - b. Turn INOMax DS<sub>IR</sub> Plus MRI backup switch ON.
  - c. Allow monitored values to stabilize.
  - d. Verify monitored values on the INOMax DS<sub>IR</sub> Plus MRI:

NO (ppm)	14 - 26
NO <sub>2</sub> (ppm)	≤ 1.0

- e. Turn backup switch OFF.



**WARNING:** This reference card is not a substitute for the INOMax DS<sub>IR</sub> Plus MRI and INOblender Operation and Maintenance manuals. Refer to these manuals for all applicable cautions and warnings.

## Pre-Use Checkout continued

### 7. Performance Test:

- a. Verify pre-use assembly O<sub>2</sub> flowmeter is set to 10 L/min.
- b. Set INOMAX dose to 40 ppm.
- c. Verify monitored values on the INOmax DS<sub>IR</sub> Plus MRI:

Acceptable NO Value (ppm)	35 - 45
Acceptable NO <sub>2</sub> Value (ppm)	< 1.5
Acceptable FiO <sub>2</sub> (%)	95 ± 3

- d. Set INOMAX dose to 0 ppm.
  - “Set Dose is Zero, Please Close Cylinder Valve” reminder will appear- DO NOT close cylinder valve at this time, dismiss reminder.
- e. Turn pre-use assembly O<sub>2</sub> flowmeter OFF.

### 8. INOblender Test:

- a. Remove injector module from pre-use assembly and reconnect tubing.
  - b. Remove O<sub>2</sub> tubing from flowmeter and attach to INOblender outlet.
  - c. Set INOblender flow to 10 L/min, INOMAX dose to 40 ppm.
  - d. Verify monitored values on the INOmax DS<sub>IR</sub> Plus MRI.
- |                           |         |
|---------------------------|---------|
| Acceptable NO Value (ppm) | 32 - 48 |
|---------------------------|---------|
- e. Set INOblender dose and flow to 0.
  - f. If device is not used within 10 minutes, depressurize cylinder regulator.

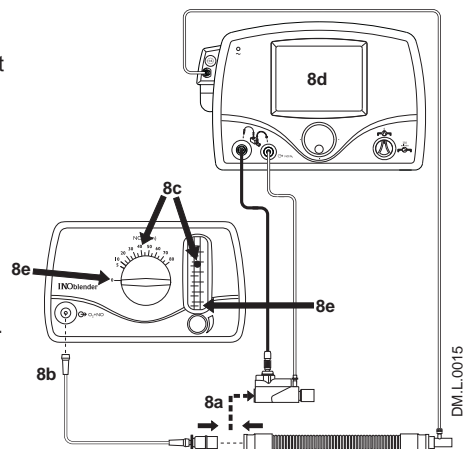

End of Procedure

## Pre-Use Assembly

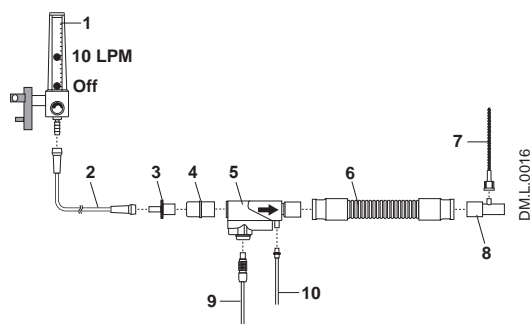

1. O<sub>2</sub> Flowmeter
2. O<sub>2</sub> Tubing
3. 15M x 4.5 mm Adapter
4. 22M / 15F x 22M / 15F Adapter
5. Injector Module
6. 300 mm of 22 mm hose
7. Patient Gas Sample Line with Nafion
8. Gas Sample Tee
9. Injector Module Electrical Cable
10. NO/N<sub>2</sub> Injector Tube

## FiO<sub>2</sub> Dilution and Cylinder Duration Tables

### FiO<sub>2</sub> Dilution

		Set FiO <sub>2</sub>				
		800	.21	.40	.60	.80
INOMAX Dose (ppm)	5	0.21	0.40	0.60	0.80	0.99
	10	0.21	0.40	0.59	0.79	0.99
	20	△ 0.20	0.39	0.59	0.78	0.98
	40	△ 0.20	0.38	0.57	0.76	0.95
	80	△ 0.19	0.36	0.54	0.72	0.90
	<b>Actual FiO<sub>2</sub></b>					

△ Caution FiO<sub>2</sub> less than 21%

### “88” Cylinder Duration

800		FLOW			
		5 L/min	10 L/min	20 L/min	40 L/min
INOMAX Dose (ppm)	5	39 Days	19.5 Days	9.8 Days	4.9 Days
	10	19.4 Days	9.7 Days	4.8 Days	2.4 Days
	20	9.6 Days	4.8 Days	2.4 Days	1.2 Days
	40	4.7 Days	2.3 Days	1.2 Days	14 Hours
	80	2.2 Days	1.1 Days	13.3 Hours	6.6 Hours



All calculations in the table above are based on a full cylinder, 128 bar (1850 psig), 1963 liter “88” cylinder, with a cylinder change at 14 bar (200 psig). The figures are calculated based on a total continuous breathing circuit gas flow and a cylinder conversion factor of 15.7 liters per bar (1.08 liters per psig).

- INOMAX flow = [Desired dose × total ventilator flow] ÷ [Cylinder concentration - desired dose]
- Cylinder volume = Cylinder conversion factor × cylinder pressure (bar/psig)
- Cylinder duration (hours) = (Cylinder volume ÷ INOMAX flow rate) ÷ 60

 **WARNING:** This reference card is not a substitute for the INOMax DS<sub>IR</sub> Plus MRI and INOblender Operation and Maintenance manuals. Refer to these manuals for all applicable cautions and warnings.

## MR Scanner Room

**WARNING:** Do not exceed 100 Gauss, system operation may be impacted. Confirm cart auto-brake function. Optionally connect tether.

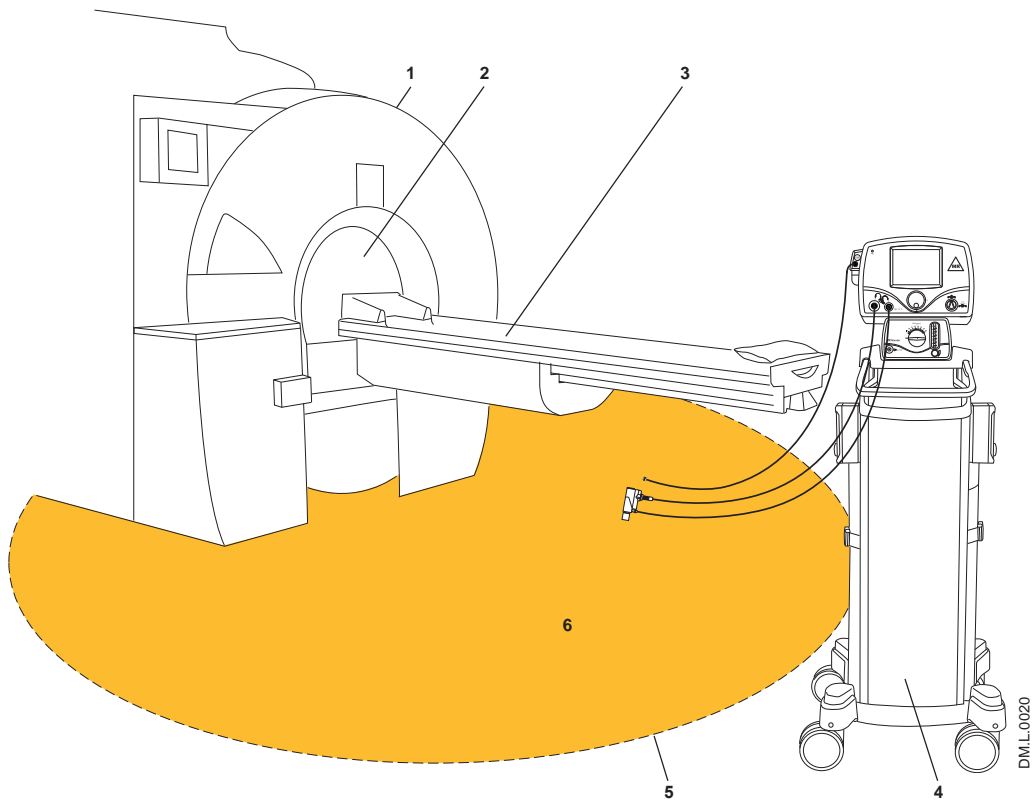

1. MR Scanner
2. MR Scanner Bore
3. Patient Table
4. INOmax DS<sub>IR</sub> Plus MRI
5. 100 Gauss Line
6. Exclusion Zone (illustration purposes only, actual shape will vary)